



Product information presented here reflects conditions at time of publication. Consult factory regarding discrepancies or inconsistencies.

MAIL TO: P.O. BOX 16347 • Louisville, KY 40256-0347  
SHIP TO: 3649 Cane Run Road • Louisville, KY 40211-1961  
(502) 778-2731 • 1 (800) 928-PUMP • FAX (502) 774-3624

visit our web site:  
[www.zoeller.com](http://www.zoeller.com)

### COMPARE THESE FEATURES

- Castings - Model 137, all cast iron ASTM class 25, 25000# tensile strength. Model 139, all bronze.
- Non-Clogging vortex impeller design.
- Corrosion resistant powder coated epoxy finish.
- Float operated 2-pole mechanical switch. (Automatic units only)
- Durable cast construction. Cast switch case, motor and pump housing, base and impeller. No sheet metal parts to rust or corrode.
- Motor - 60 Hz, 1725 RPM, oil-filled, hermetically sealed, automatic reset thermal overload protected (1 Ph).
- Upper and lower sleeve bearings running in bath of oil.
- Carbon and ceramic shaft seal.
- Stainless steel screws, bolts, handle, guard, and arm and seal assembly.
- UL Listed 3-wire neoprene cord and plug. 10 ft. standard for automatic. 15 ft. standard for nonautomatic.
- Maximum temperature for effluent or dewatering—130°F - 54°C (Extra Duty 140°F - 60°C).
- Passes 5/8 inch spherical solids.
- No screens to clog.
- 1½" NPT Discharge. (1½" x 2" PVC adapter fitting included with BN and BE models).
- On point—10". Off point—2¾".

**AVAILABLE SYSTEMS:**  
**SIMPLEX AND DUPLEX SYSTEMS**  
**PACKAGED SYSTEMS**  
**VARIABLE LEVEL CONTROL SYSTEMS**  
**DESIGNED FOR HEAVY DUTY EFFLUENT APPLICATIONS**

**Note:** The sizing of effluent systems normally requires variable level float(s) controls and properly sized basins to achieve required pumping cycles or dosing timers with nonautomatic pumps.

## 137 Cast Iron Series 139 Bronze Series



(For Pump Prefix Identification see News & Views 0052)

# "FLOW-MATE"

FOR SEPTIC TANK - LOW PRESSURE PIPE (LPP)  
AND ENHANCED FLOW STEP SYSTEMS



Tested to UL Standard UL778

**EFFLUENT  
OR DEWATERING PUMPS  
SUBMERSIBLE  
1½" NPT DISCHARGE**



Model M137



Vortex Type Impeller



Certified to CSA Standard C22.2 No.108

Model BN137

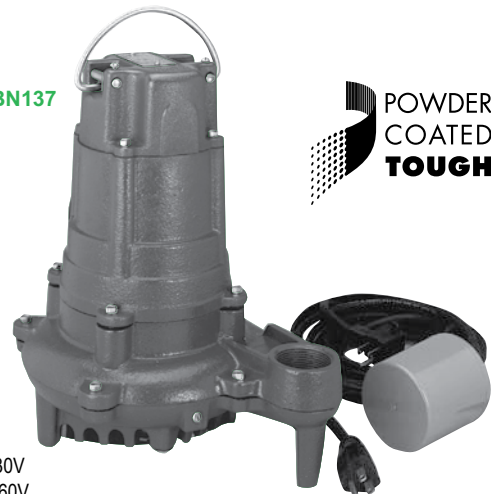

### MODELS AVAILABLE

- Automatic
- Nonautomatic
- ½ HP, 1 Ph, 115V, 200-208V or 230V
- ½ HP, 3 Ph, 200-208V, 230V, or 460V

\* NOTE: See back page for UL & CSA Listings.

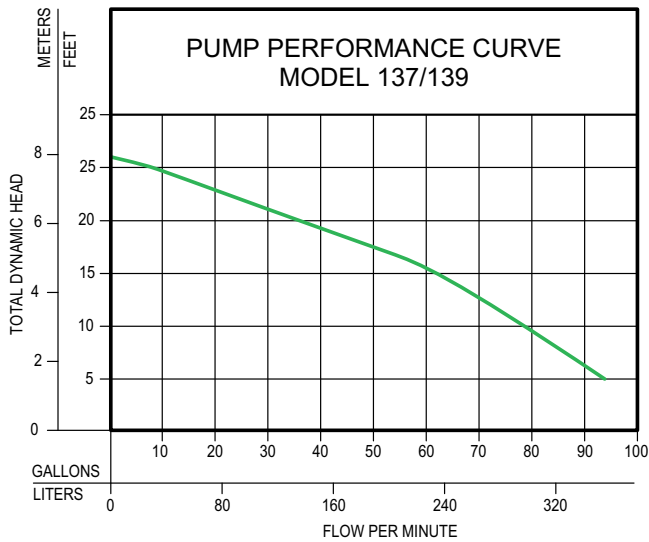

TOTAL DYNAMIC HEAD/FLOW PER MINUTE EFFLUENT AND DEWATERING

MODEL		137/139	
Feet	Meters	Gal.	Liters
5	1.5	93	352
10	3.0	79	299
15	4.6	64	242
20	6.1	36	136
25	7.6	8	30
Shut-off Head:		26 ft.(8.0m)	

009921

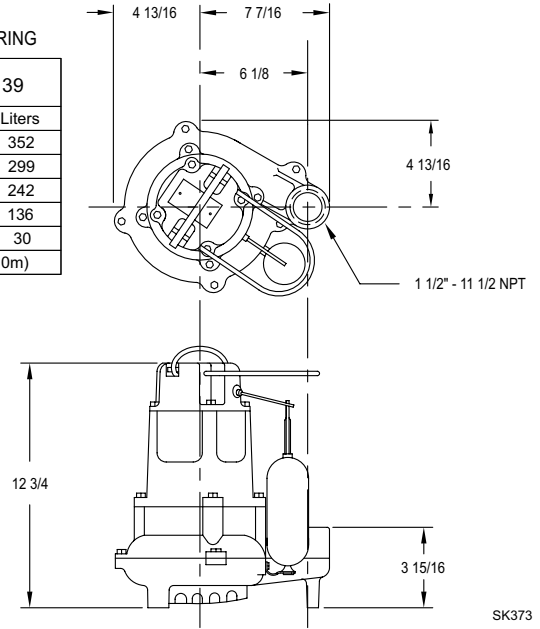

SK373

## CONSULT FACTORY FOR SPECIAL APPLICATIONS

- Three phase pumps are available in 200/208V, 230V or 460V.
- Electrical alternators, for duplex systems, are available and supplied with an alarm.
- Mechanical alternators, for duplex systems, are available with or without alarm switches.
- Simplex Panels are available for 3 phase pumps.
- Control alarm systems are available for 1 phase pumps.
- Variable level control switches are available for controlling single and three phase systems.
- Double piggyback variable level float switches are available for variable level long cycle controls.
- Over 130°F (54°C) special quotation required.
- Refer to FM1922 and FM0806 for temperatures over 130°F.

### 137 Series - 47 lbs. 139 Series - 51 lbs.

Single Seal Model	Control Selection						Listings	
	Volts-Ph	Mode	Amps	Simplex	Duplex	CSA	UL	
M137/139	115	1	Auto	10.7	1	4	Y	Y
N137/139	115	1	Non	10.7	2 or 3	2 or 4	Y	Y
** BN137	115	1	Auto	10.7	**	4	Y	Y
D137/139	230	1	Auto	5.8	1	4	Y	Y
E137/139	230	1	Non	5.8	2 or 3	4	Y	Y
* H137/139	200-208	1	Auto	6.2	3	4	Y	N
* I137/139	200-208	1	Non	6.2	3	4	Y	N
* J137/139	200-208	3	Non	2.6	3	4	Y	Y
* F137/139	230	3	Non	2.6	3	4	Y	Y
* G137	460	3	Non	1.4	3	4	N	N
* G139	460	3	Non	1.4	3	4	N	N

\* No molded plug

\*\*Single piggyback switch included.

Pumps must be operated in upright position.

Three phase units require a control switch to operate an external magnetic contactor.

For information on additional Zoeller products refer to catalog on Piggyback Variable Level Float Switches, FM0477; Electrical Alternator, FM0486; Mechanical Alternator, FM0495; Alarm Package, FM0732; and Sump/Sewage Basins, FM0487.

## SELECTION GUIDE

1. Integral float operated mechanical switch, no external control required.
2. For automatic use single piggyback variable level float switch or double piggyback variable level float switch. Refer to FM0477.
3. See FM1228 for correct model of simplex control panel.
4. See FM0712 for correct model of duplex control panel or FM1663 for a residential alternator system.

### CAUTION

All installation of controls, protection devices and wiring should be done by a qualified licensed electrician. All electrical and safety codes should be followed including the most recent National Electric Code (NEC) and the Occupational Safety and Health Act (OSHA).

## RESERVE POWERED DESIGN

For unusual conditions a reserve safety factor is engineered into the design of every Zoeller pump.



www.zoeller.com

**ZOELLER**  
PUMP CO.

MAIL TO: P.O. BOX 16347  
Louisville, KY 40256-0347  
SHIP TO: 3649 Cane Run Road  
Louisville, KY 40211-1961  
(502) 778-2731 • 1 (800) 928-PUMP  
FAX (502) 774-3624

Manufacturers of..

"QUALITY PUMPS SINCE 1939"